



32T - 8x4 - 205T/M Scania

6100 kg à 19m40 en bout de flèche sans JIB

Avec JIB 1800 kg à 31,5m en bout de flèche

Avec Double JIB 200 kg à 40m50 bout de flèche

4 essieux pour 9m60 de longueur

Plateau 4m de long et 1m45 de hauteur

Possibilité d'atteler une remorque



Schéma technique

Diagramme de capacité



Diagramme de capacité

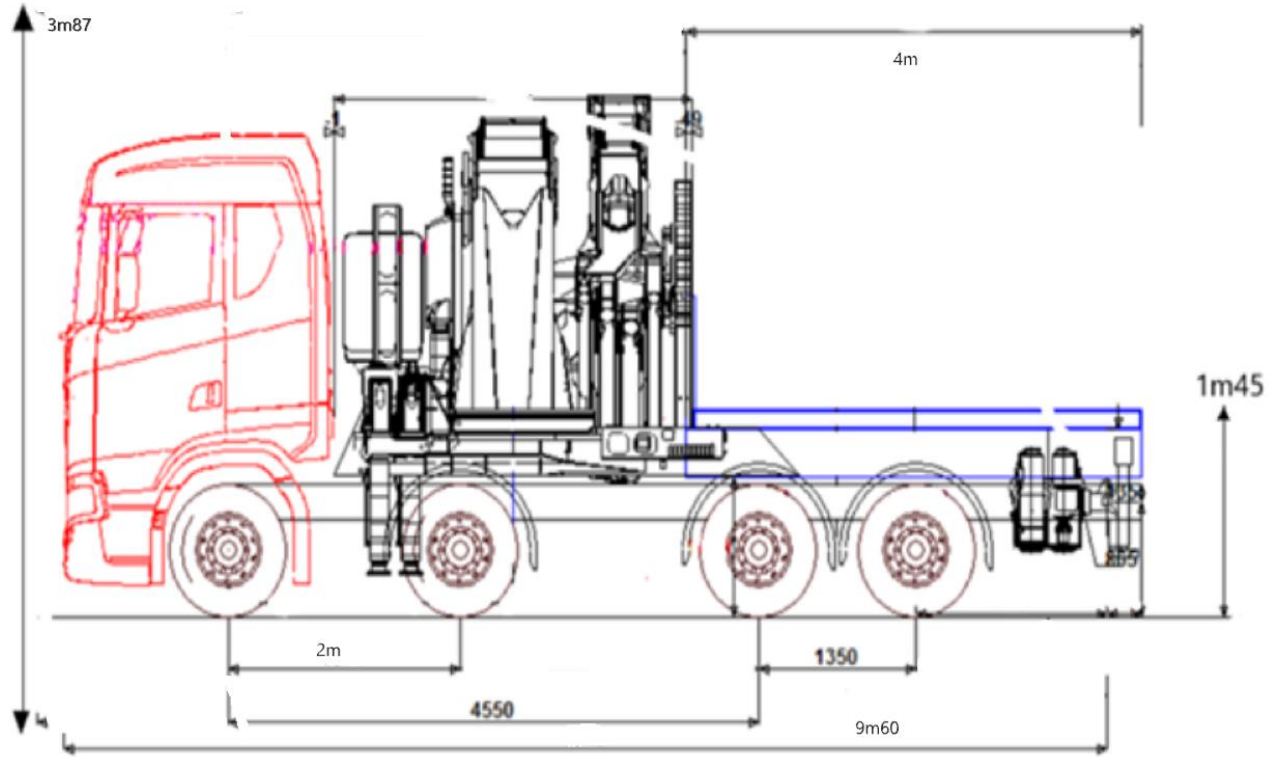

JIB400E

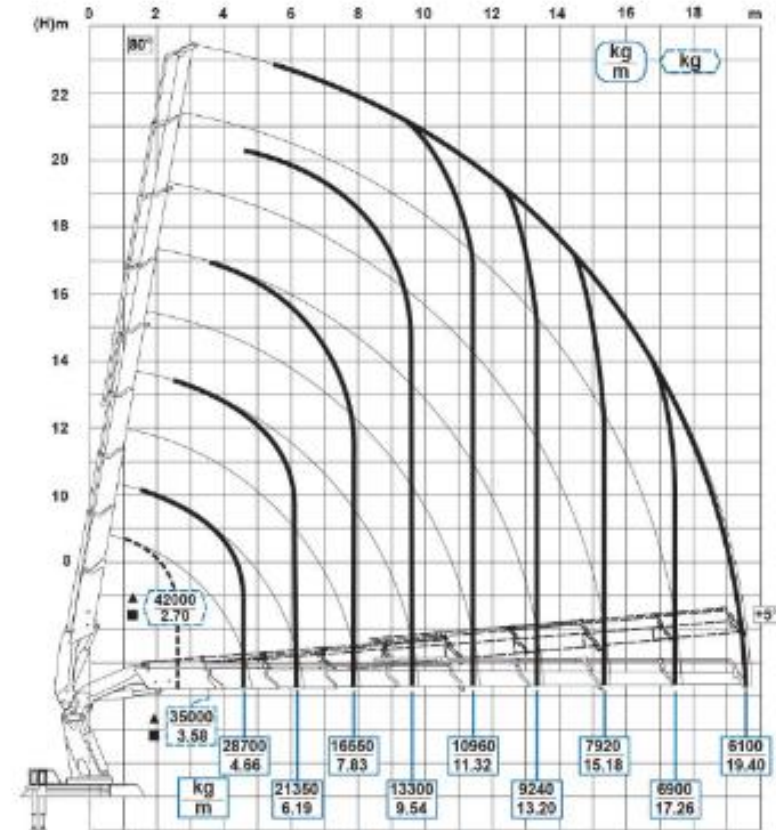
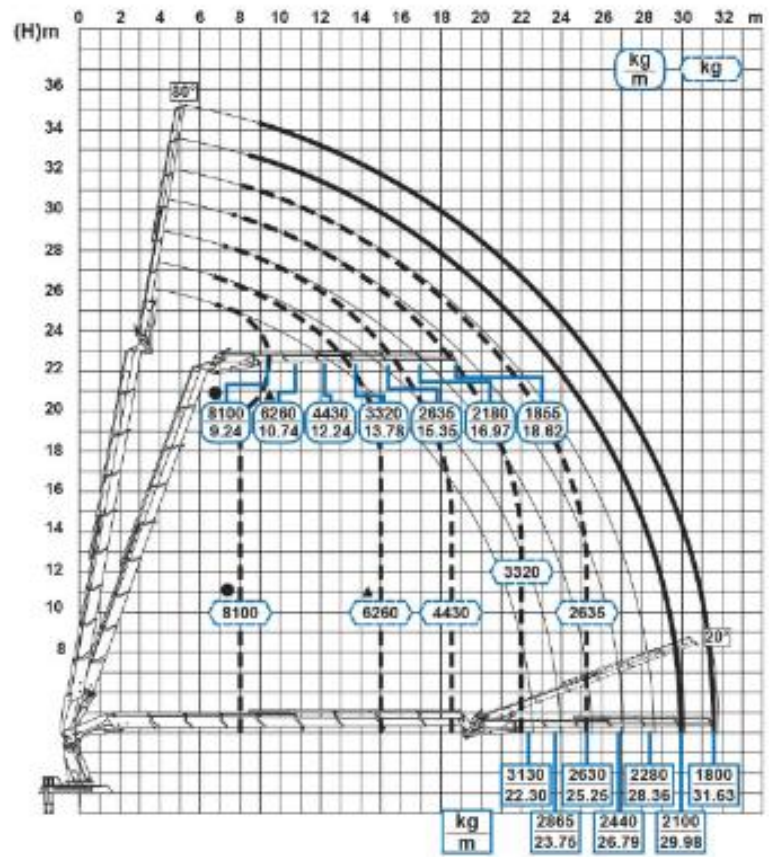

TLM 2008
TRANSPORT - LEVAGE - MANUTENTION

Diagramme de capacité

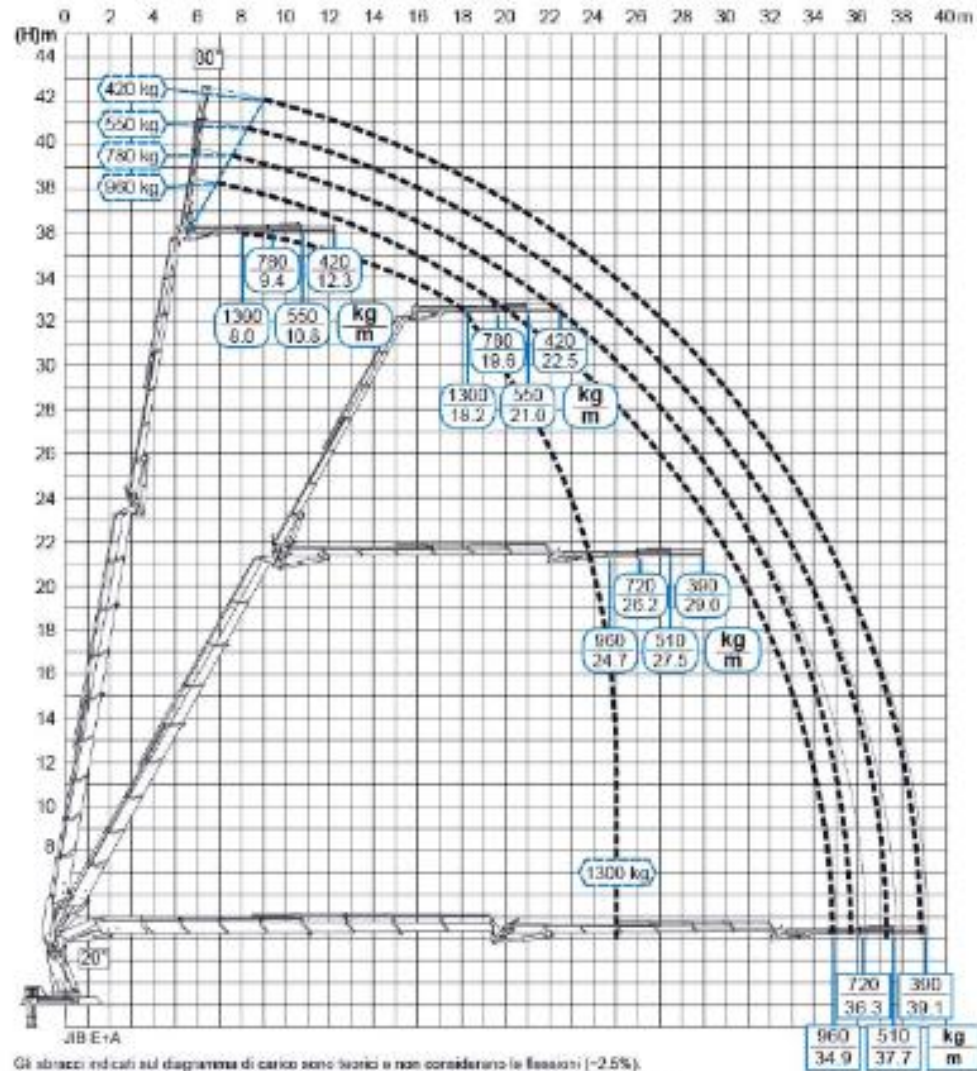

Gli sbalzi indicati sul diagramma di carico sono teorici e non considerano le flessioni (-2.5%).
The outreaches indicated in the diagram are theoretical and do not consider boom flexing (-2.5%).

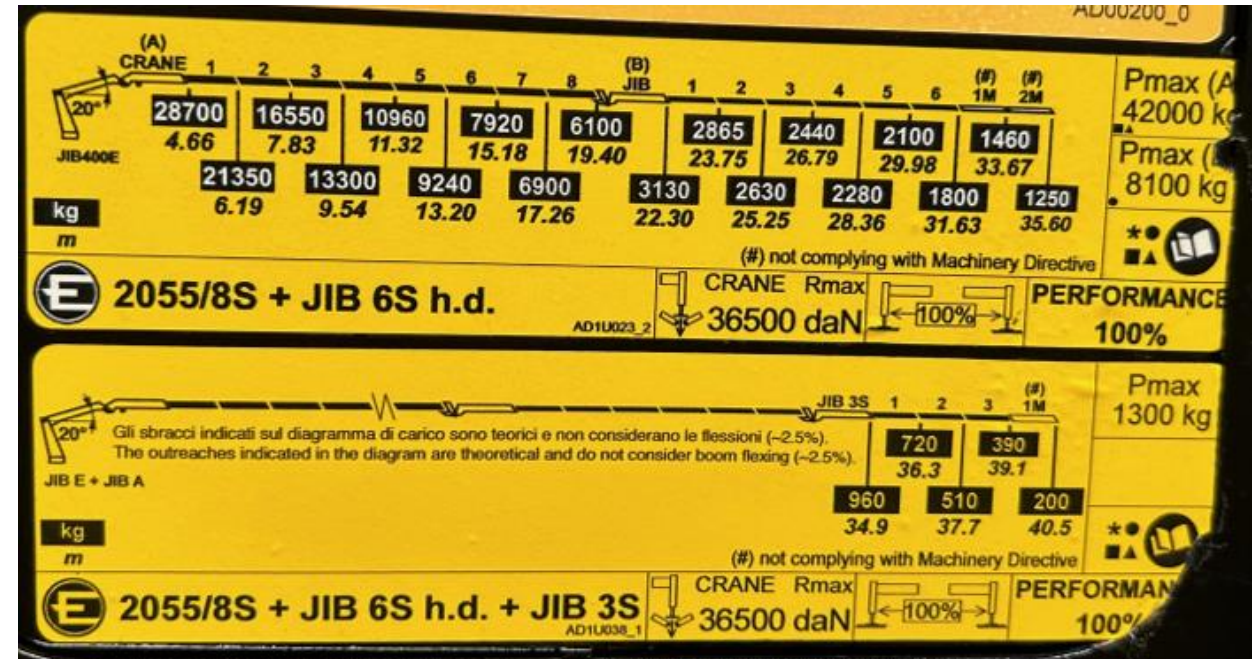

TLM 2008
 TRANSPORT - LEVAGE - MANUTENTION

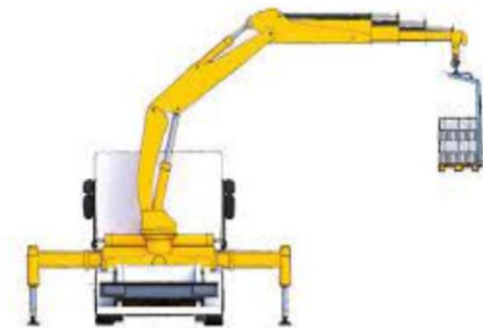

Avant : 3m90 / Arrière : 3m90